

بسم الله الرحمن الرحيم

منظمة براكتكال أكشن – السودان

التاريخ: 15 مارس 2021

عطاء رقم (PR106.-UKAM) – FY21

عطاء تشييد مضخة يدوية

بولاية شمال دارفور

براكتكال أكشن منظمة دولية متفردة باستخدامها أفكاراً خلاقية ومبتكرة لتحويل واقع الإنسان في الدول النامية إلى الأفضل، نعمل في مكاتب إقليمية في المملكة المتحدة، أفريقيا، آسيا، وأمريكا اللاتينية.

بدأت منظمة براكتكال أكشن العمل في السودان وتم تسجيلها بصفة مستقلة كمنظمة دولية غير حكومية في العام ١٩٩٢، للمنظمة مكاتب وبرامج في ولايات شمال دارفور، كسلا و النيل الأزرق.

ترغب منظمة براكتكال أكشن من الموردين والشركات الكفاء بتقديم عروضهم لتشييد عدد (1) مضخة يدوية بولاية شمال دارفور ، وفقاً للشروط و المواصفات الواردة بكراسة العطاء.

على المتقدمين للعطاء ارفاق المستندات الموضحة ادناه:

- 1/ السيرة الذاتية للشركة
- 2/ شهادة مقدرة مالية بتاريخ السنة المالية للعطاء.
- 3/ صورة من شهادة خلو طرف من الضرائب بتاريخ السنة المالية، ومن يرسو عليه العطاء ملزم باحضار الاصل.
- 4/ شهادة تسجيل من المسجل التجاري
- 5/ شهادة تسجيل ضريبة على القيمة المضافة.
- 6/ كشف حساب بنكي لآخر ستة اشهر حتى تاريخ العطاء.
- 7/ ملء و ارفاق كراسة العطاء مشتملة على كل التفاصيل المطلوبة.
- 8/ خطاب مروس من الجهة المتقدمة للعطاء معنون لمنظمة براكتكال أكشن يحتوى على (تأكيد نوع وكميات الخدمة المطلوبة / المبلغ الكلى للعطاء شامل القيمة المضافة/الزمن المقرر لاكمال تقديم الخدمة في الموقع/ اسم و عنوان و تليفون و توقيع الشخص المفوض من قبل الجهة المتقدمة للعطاء).
- 9/ تقدم المستندات اعلاه في ظرف مغلق بالشمع الاحمر ومكتوب عليه (مرفق استيكر هذه البيانات و يجب ان يلصق على ظرف العطاء -راجع الفقرة 6 من شروط كراسة العطاء). رقم العطاء/اسم العطاء / اسم مقدم العطاء و عنوانه و ارقام الهواتف.
- 10/ كل ظرف يجب ان يحتوى على عطاء واحد فقط بمعنى عدم التقديم لاكثر من عطاء في ظرف واحد.
- 11/ المستندات المقدمة للعطاء لاترد.
- 12/ اى متقدم غير مستوفى للمتطلبات اعلاه يستبعد من المنافسة.
- 13/ للحصول على كراسة العطاء (مجانياً) يرجى الاتصال بالمنظمة اثناء ساعات العمل من الساعة 8:30 صباحاً حتى الساعة 2:30 مساءً بمقر المنظمة بالخرطوم المعمورة مربع 72 مبنى رقم 12 (شارع مدني مع تقاطع الستين شمال مكتب ضرائب المعمورة) وجنوب غرب برج شركة زين للاتصالات تلفونات: 0155662476 - 0123502456 - 0155662474 او بمكتب المنظمة بالفاشر تليفون: 0912513017 0911336430.
- 14/ اخر موعد لتسليم العطاءات شهر من تاريخ ظهور الإعلان في الصحف المحلية الساعة الثانية والنصف نهاريًا بمقر المنظمة بالخرطوم او مكتب المنظمة بولاية كسلا .

المنظمة غير مقيدة بقبول أعلى أو اقل عطاء.

1. احضار ملف الشركة لمعاينته بواسطة لجنة تأهيل الموردين لضافته لكشف الموردين الخاص بالمنظمة.
2. يجب توفير الضمانات اللازمة لتنفيذ و توريد كل الاعمال المتفق عليها في العقد بالمعايير و الجودة المتفق عليها.
3. علي المتقدم ان يوضح في عطاءه الأسعار بالجنيه السودانى وان تكون الاسعار شاملة لضريبة القيمة المضافة ، وفي حال رسو العطاء لأى من المتقدمين يجب عليه تقديم فاتورة نهائية مختومة بختم الضرائب.
4. الأسعار يجب ان توضح على جداول الكميات و المواصفات وان تكون مختومة بختم الجهة المتقدمة للعطاء.
5. يجب ان تكون الاسعار الموضحة بجدول الكميات و المواصفات سارية المفعول لمدة اسبوعين من تاريخ تقديم العرض
6. يجب على المتقدم الرجوع الى شروط المناقصة والمواصفات قبل التقديم.
7. اي كشط او تعديل في الاسعار الموضحة في جداول الكميات و المواصفات غير موقع ومختوم بواسطة المتقدم بالعطاء يحرمه من دخول المناقصة .
8. لجنة فرز العطاءات والمناقصات لها الحق كاملاً في الغاء العطاء او المناقصة متى ما رأت ذلك ضروريا او لاي اسباب اخرى فنيه تراها اللجنة.
9. على الراغبين تقديم العطاءات في ظروف مقفولة و مختومة بالشمع الاحمر توضع في صندوق المناقصات بمكاتب المنظمة بالعناوين الموضحة في صفحة واحد الفقرة 13.
10. آخر يوم لتقديم العطاءات شهر من تاريخ ظهور الإعلان في الصحف المحلية الساعة الثانية والنصف نهارا ولن تقبل اي عطاءات بعد التاريخ و الزمن المحددين.
11. الرجاء مل اخطار المناقصة المدمج في كراسة العطاء لتوحيد مواصفات العطاء لكل الموردين المتقدمين للمنافسة والتوقيع والختم عليه مع توضيح طريقة الدفع (كاش / شيك / تحويل) ورقم الحساب البنكى , اى عطاء لايتحوى على كراسة العطاء مكتملة سوف يبعد من المنافسة.
12. في حالة عدم تقديم الموردين المعتمدين بكشف المنظمة يرجى الاعتذار كتابة مع رد مستندات العطاء ، وفي حالة الاخلال بهذا الشرط سوف يتم استبعاد المورد من كشف الموردين الخاص بالمنظمة.
13. للمنظمة الحق في اضافة أو تقليل الكميات الموصوفة في جدول الكميات و بنفس أسعار العقد في زمن تنفيذ العقد.
14. علي المتقدم في حالة مخالفة المواصفات المطلوبة و المنصوص عليها في كراسة العطاء ذكر ذلك كتابة و تفصيلا لتوضيح اسباب التقديم بعرض مخالف للمواصفات.
15. للمنظمة الحق في التعاقد مع مورد واحد أو أي عدد من الموردين حسب ما تراه مناسباً لها .
16. للمنظمة الحق في مراجعة الوحدات الموردة و التأكد من جودة تنفيذها ومطابقتها للمواصفات المطلوبة
17. للمنظمة الحق في رفض استلام اي من الكميات المتفق عليها في العقد غير مطابق للمواصفات المطلوبة حسب شهادة المختصين ممن تكلفهم المنظمة بالإستلام علي أن يتحمل المورد اي خسارة تنتج عن ذلك وتخصم من حسابه طرف المنظمة.
18. يتم الدفع حسب شروط العقد المتفق عليها وتحرر شهادة استلام بذلك طبقاً للمواصفات المرفقة مع المناقصة والتقييم الفنى.
19. من يرسو عليه العطاء ملزم بملء معلومات رقم حسابه البنكى كتابة لتحويل قيمة العطاء بصورة صحيحة و المنظمة غير مسؤولة عن اي خطأ ينتج من المورد فيما يختص برقم حسابه.
20. من يرسو عليه العطاء ملزم بتوقيع اشعار استلام سياسات المنظمة الخاصة بحماية المنظمة من الجرائم المالية وذلك لمنع هدر موارد الماتحين بغرض المحافظة على قيمة مال الماتحين. كما ينبغى على الموردين الالتزام بملئ استمارة تقييم (الشركاء والموردين ومقدمى الخدمات) وارجاعها للمنظمة لاكمال ملف المورد قبل اجراءات الدفع, وسياسات المنظمة الاخرى المتعلقة بالالتزام بالانذاره ومناهضة و مكافحة الرشوة والغش والاختلاس وذلك لضمان و تاكيد التزام المنظمة وكل الشركاء والاطراف التى تتعامل معها المنظمة من موردين ومقدمى خدمات

Practical ACTION

براكتكال أكشن

ملتزمون بتطبيق هذه السياسات وان اى خصم او تخفيض فى قيمة السلع او الخدمات من قبل المورد يجب ان يوضح كتابة لعدم اهدار موارد

المنظمة و تقليل التكاليف لاقصى حد لفائدة برامج ومشاريع عمل المنظمة ولتقليل هدر موارد المانحين.

21. المنظمة غير ملزمة بقبول أدنى أو إي عطاء آخر ولها حق رفض أي عطاء حسب لوائح المنظمة .

22. على من يرسو عليه العطاء احضار اى مقترحات او عينات ان وجدت لمعاينتها من قبل الجهة الفنية لاعتمادها قبل الشروع فى عملية التوريد و التنفيذ.

23. من يرسو عليه العطاء يلتزم بترحيل المواد المتفق عليها فى العقد (ان وجد)الى المكان المتفق عليه مسبقا. دون اى تأخير, التأخير غير المبرر يؤدى الى الغاء العقد الموقع بين المنظمة و المورد دون اى قيد او شرط.

24. تتم عملية التسليم و التسلم النهائية بعد التأكد من توافق الكميات الموردة والخدمة مع المواصفات المطلوبة بحسب الراى الفنى للمختص من طرف المنظمة.

25. من يرسو عليه العطاء يلتزم بتدريب الفنيين العاملين بالمشروع و المستفيدين على النواحي الفنية وغيره (ان وجدت).

26. المستندات المقدمة من قبل الموردين لا ترد .

27. معايير اختيار المود تتضمن وليس بالضرورة ان تقتصر على افضلية السعر التنافسى وجودة السلع والخدمات مع افضلية زمن التسليم وطريقة الدفع الامن من اولويات معايير لجنة المشتريات فى الاختيار بالاضافة الى معايير اخرى تراها اللجنة بحسب نوع العطاء.

Practical Action - North Darfur

UK-Aid Match Project: Building Climate & Conflict Resilient Livelihoods Project

Terms of Reference

Construction of Hand pumps HPs for livestock watering in the migratory routes

1. Introduction:

UK-Aid Match project is aiming to integrating climate change adaptation and peace building to help communities in North Darfur to be more resilient to climate/fragility risk. The project is implemented by Practical Action (INGO) in a partnership with local NGOs, funded by Department for International Development (DIFID), and involving numbers of stakeholders (government bodies and Community-Based Organizations CBOs). The project targeting 20 Village Councils including; Kulkul, Krgo-nronga, Ghairban (A), Grban (B), Tura (B)- Um-Lawta, Abu-Nahla (A), Azagrfa, Goaz Hai, Um-Gudoul and Garni, Kobi El-Gadi, Finga, Birka, Goz, El-Niem, Dierma Tartora Birka Galo, Abu-SimnitFalata, Um-Asal and Maagla.

2. UK-Aid Match Project Goal:

Rural Communities, including farmers, agro-pastoralists and pastoralists, have livelihoods that are resilient to the effects of climate change and conflict.

3. UK-Aid Match Project Objective:

35,600 vulnerable rural people including women, men, girls and boys in North Darfur have improved food security, increased income.

4. Objective of the Activity:

Installation of one HP for livestock watering in the migratory routes is an activity coded by (2.1.7) in Project budget, this activity intended to achieve its objectives which include:

- Identifying potential areas that need establishing Installation of HPs;
- Installation of one Hand pump which include well digging HP system purchase and installation.

1- Drilling and Installation:

The location need to prepare for Hydro geological studies and Geophysical survey to determine the location of drilling borehole.

-From the studies and Geophysical survey locating of what Mechanical Method of drilling (Hammer, Rotary etc), in additional choice three (VES) from best (VES) Drilling the borehole if dry is going to other (VES).
-The drilling and Installation of Hand pumps includes all supplies that needs (Conductors, pipes Casing, screens...etc.)

2- Water Quality Test.

Practical ACTION

پراکٹیکل ایکشن

A sample of water from the borehole shall be taken at the end of the cleaning and airlifting the borehole for chemical. Physical and bacteriological analyses, the sample container shall be clean and clearly marked showing the name of the community, number of the borehole, and date of sampling. The chemical analysis shall determine the following: pH, temperature, color, chloride, total nitrates, sulphate, fluoride, manganese, lead, zinc, copper, arsenic, total iron, total hardness, total dissolved solids, and total suspended solids. The bacteriological analysis shall determine total coliform and total fecal coliform. Temperature and pH shall be measured when samples are taken.

Specification & Bill of quantities (construction of one Hand pumps)

#	DESCRIPTION	Qty	Unit	Unit cost	Total cost
1	Hydrogeology studies and Geophysical survey	1	L.s		
2	Final Report of Studies	1	L.s		
3	Movement of drilling unit to location	1	L.s		
4	Drilling by drag bit 10 inch from ground level to expected depth of Basement.	15	M		
5	Drilling by hammer bit 6 inch from Basement to end expected depth of Fracture rock zone.	50	M		
6	Provision and Installation of Pipe (U.P.V.C) 10 bar 8 inch (Conductor casing) 3 m length	6	No		
7	Provision and Installation of Pipe (U.P.V.C) 10 bar 5,5 inch (Plain casing) 3 m length	17	N.o		
8	Provision and Installation of Pipe (U.P.V.C) 10 bar 5,5 inch (Slotted screen) 3 m length	4	N.o		
9	Air lifting by compressor (clean the borehole)	1	L.s		
10	Chemical. Physical and bacteriological analyses, the sample container shall be clean and clearly marked showing the name of the community, number of the borehole, and date of sampling.	1	N.o		
11	Provision and Installation of complete set Hand pump (hp body , handle , raising pipe 1¼ " , cylinders ,.....etc) with construction of round shaped drainage basin , diameter of 2 meter , with channel 7 meter by concrete cement and bricks	1	L.s		
12	Supply and construction of basin in the end of drainage system of hand pump for animals of Dimension (2×1) m and depth (0, 5) m by bricks, iron and cement.	1	work		
13	Supply and Installation of manufactured from expended metal lockable fixed on 2 inch angled iron which is welded to 4 inch posts pipe (1, 5 meter height) with gate.	12	meter		
14	Labor cost	1	work		
15	Final Report				
	Sub total				
	VAT %				
	Transportation cost if any				
Total					

Design of Drilling and Installation of Borehole

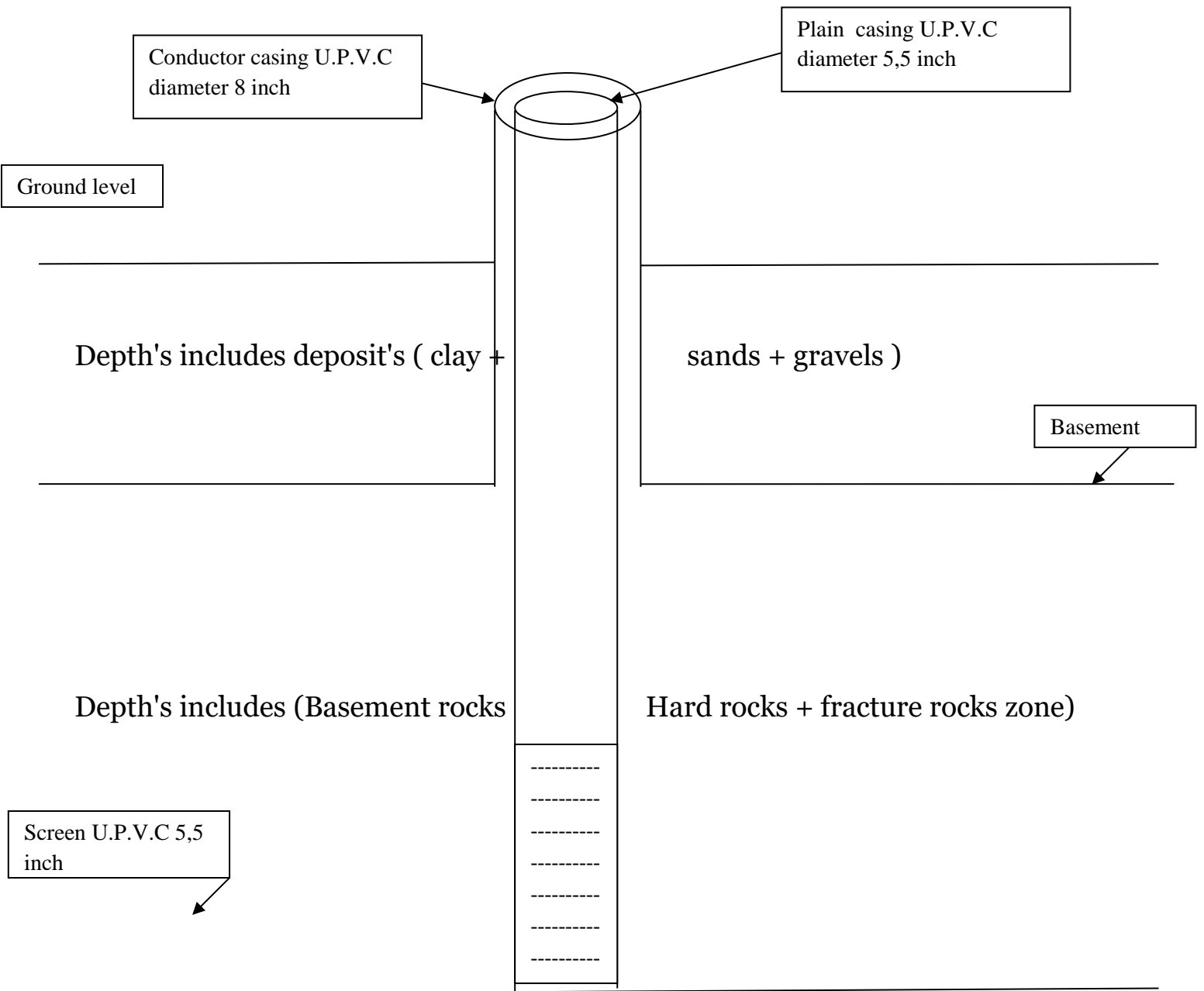

Design of Installation of hand pump

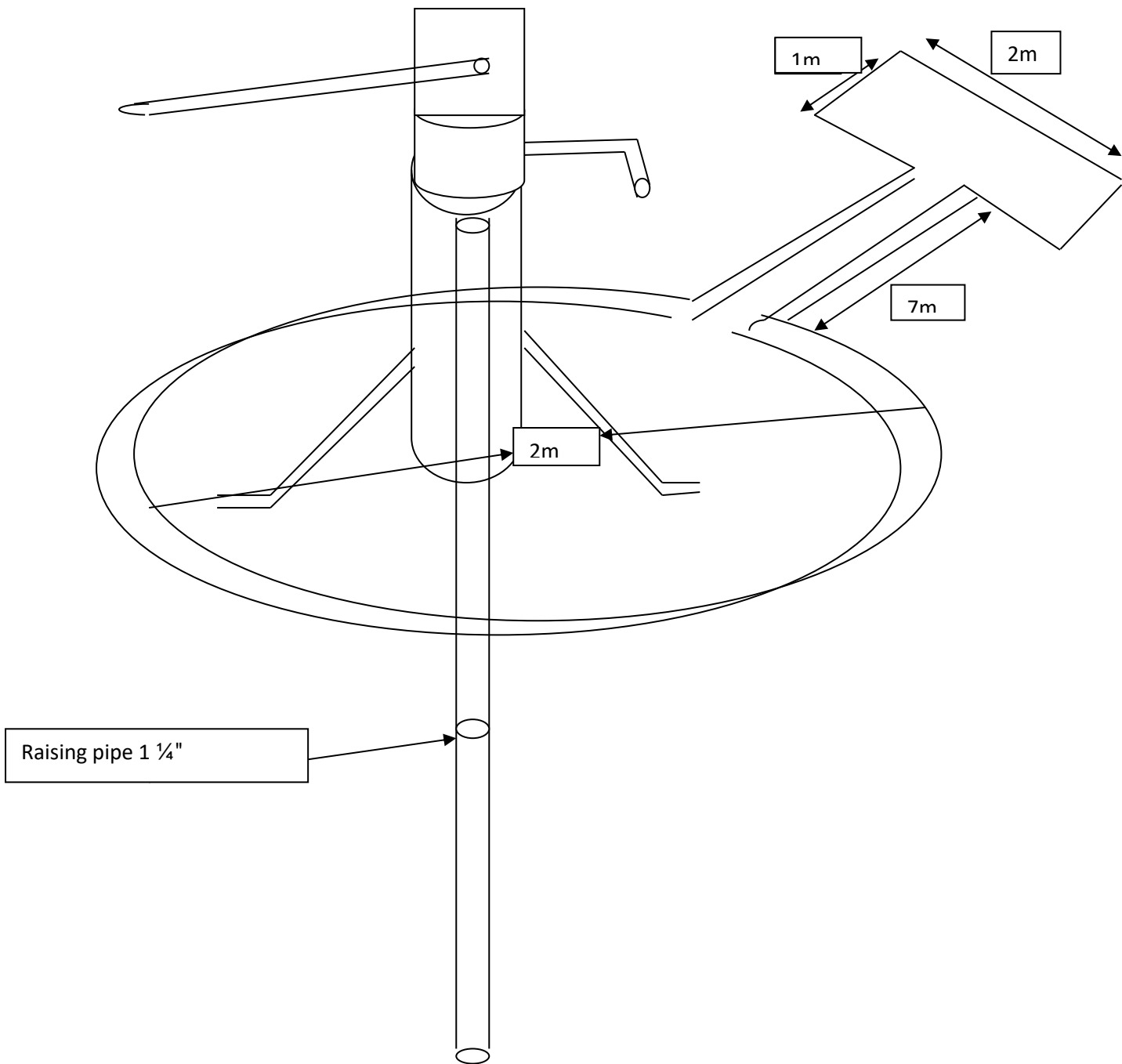

ثالثاً: التكاليف وزمن تسليم الخدمة بالموقع وتفاصيل المورد:

..... المبلغ الكلي بالارقام بالجنيه السوداني :
..... المبلغ الكلي بالجنيه بالحروف
..... الزمن المقدر لإنجاز واكمال وتسليم الخدمة بالموقع :
..... اسم الشركة / المورد:
..... العنوان:
..... اسم من ينوب عن الشركة:
..... الوظيفة:
..... التوقيع:
..... الختم:
..... البريد الالكتروني:
..... الهاتف:

Annex: 1

Practical Action Terms and Conditions for Supply, Service and Works Contracts

1. LEGAL STATUS

The Vendor shall be considered as having the legal status of an independent contractor vis-à-vis PA.

The Vendor, its personnel and sub-contractors shall not be considered in any respect as being the employees of PA.

The Vendor shall be fully responsible for all work and services performed by its employees, and for all acts and omissions of such employees.

2. SUB-CONTRACTING

In the event the Vendor requires the services of a sub-contractor, the Vendor shall obtain the prior written approval of PA for all sub-contractors. The Vendor shall be fully responsible for all work and services performed by its sub-contractors and vendors, and for all acts and omissions of such sub-contractors and vendors. The approval of PA of a sub-contractor shall not relieve the Vendor of any of its obligations under this Contract. The terms of any sub-contract shall be subject to and conform to the provisions of this Contract.

3. OBLIGATIONS

The Vendor shall neither seek nor accept instructions from any authority external to PA. Vendors may not communicate at any time to any other person, government or authority external to PA any information known to them by reason of their association with PA which has not been made public, except in the course of their duties or by authorization of the PA: nor shall Vendors at any time use such information to private advantage. These obligations do not lapse upon termination/expiration of their agreement with PA.

4. ACCEPTANCE AND ACKNOWLEDGEMENT

Initiation of performance under this contract by the vendor shall constitute acceptance of the contract, including all terms and conditions herein contained or otherwise incorporated by reference.

5. WARRANTY

The Vendor warrants the goods furnished under this Contract to conform to the specifications and to be free from damage and defects in workmanship or materials. This warranty is without prejudice to

Any further guarantees that the Vendor provides to purchasers. Such guarantees shall apply to the goods subject to this Contract.

6. INSPECTION

The duly accredited representatives of PA shall have the right to inspect the goods called for under this Contract at Vendor's stores, during manufacture, in the ports or places of shipment, and the Vendor shall provide all facilities for

such inspection. PA may issue a written waiver of inspection at its discretion. Any inspection carried out by representatives of PA or any waiver thereof shall not prejudice the implementation of the other relevant provisions of this Contract concerning obligations subscribed by the Vendor, such as warranty or specifications.

7. EXPORT LICENCE

The Contract is subject to the obtaining of any governmental authorization that may be required. It shall be the responsibility of the Vendor to obtain such license or authorization. PA may, at its discretion, use its best endeavors to assist.

8. OFFICIALS NOT TO BENEFIT

The Vendor represents and warrants that no official of PA has been, or shall be, offered by the Vendor any direct or indirect benefit arising from this Contract or the award thereof. The Vendor agrees that breach of this provision is breach of an essential term of this Contract.

9. DEFAULT

In case of default by the Vendor, including, but not limited to, failure or refusal to make deliveries within the limit specified, PA may procure the goods or services from other sources, and hold the Vendor responsible for any excess cost occasioned thereby. Furthermore, PA may, by written notice, terminate the right of the Vendor to proceed with deliveries or such part or parts thereof as to which there has been default.

10. REJECTION

In the case of goods or services purchased based on specifications or scope of works, PA shall have the right to reject the goods or services or any part thereof if they do not conform to specifications or the scope of works.

11. AMENDMENTS: No change in or modification of this Contract shall be made except by prior agreement between the Responsible Buyer in PA in Sudan and the Vendor.

12. ASSIGNMENTS: The Vendor shall not assign, transfer, pledge or make other disposition of this Contract or any part thereof or of any of the Vendor's rights, claims or obligations under this Contract except with the prior written consent of PA.

ADDENDUM TO PARTNER AGREEMENT

1. PURPOSE

1.1 This is an Addendum to Agreement No. _____ concluded between Practical Action and [NAME OF ORGANISATION], the Partner, which came into force on [date of start of agreement].

1.2 This Addendum forms an integral part of the Agreement, including all its other terms and conditions

1.3 By signing this Addendum, the Partner agrees to ensure that all its staff, consultants, partners, volunteers and trustee comply with all the terms and conditions included herein and which form part of the original Agreement between Practical Action and the donor and are an integral part of Practical Action's policies and code of conduct.

2. PROTECTION OF CHILDREN AND VULNERABLE ADULTS

Practical Action firmly believes that no person, including children and vulnerable adults, should be subjected to exploitation or abuse at any time. We are committed to ensuring that all our staff, partners, consultants, volunteers and trustees fully abide by our Policy on the Protection of Children and Vulnerable Adults at all times. Within the Partner, this policy applies to all staff, volunteers, consultants, or sub-partners who are involved with this project in any way.

The Partner commits to:

2.1 Fully integrate the Policy within your organisation ensuring that the policy is adopted and procedures and capabilities are developed to prevent the abuse or exploitation of children and vulnerable adults in your work, implement a clear and effective reporting system for any concerns

Or incidents of exploitation or abuse and define robust management processes for handling any concerns or incidents, OR

2.2 Confirm to Practical Action that you have your own robust policy on the Protection of Children and Vulnerable Adults, AND

2.3 Ensure that any concerns or incidents of exploitation and abuse of children and vulnerable adults related to the project funded by this Agreement are reported to Practical Action within 24 hours of your organisation becoming aware of them and that Practical Action, as the primary recipient of the award, is regularly informed of all actions taken in the response.

The Partner agrees that it will work with Practical Action to take disciplinary actions and to inform authorities, where appropriate. Depending on the outcomes of investigation, the Partner acknowledges that Practical Action will inform the donor and its regulatory body.

3. COMPLIANCE WITH THE LAW AND REPORTING OBLIGATIONS

Practical Action is committed to complying with all relevant laws in the UK and in all the countries where it works as well as with meeting its reporting obligations to relevant national and international bodies, including the Charity Commission for England and Wales.

By signing this Addendum, the Partner also commits to compliance with all laws in the country/ies where the work related to this Agreement is being implemented and to meeting its reporting obligations to relevant national and international bodies, including providing Practical Action with all accurate and timely information that enables Practical Action to meet all its reporting obligations.

4. CONFLICT OF INTEREST

Neither the Partner, nor any individual employed or contracted by the Partner, shall engage in any business, personal or professional activity which conflicts or could conflict with any of their obligations in relation to this Agreement.

5. FRAUD, CORRUPTION, BRIBERY, THEFT, TERRORIST FINANCING AND OTHER MISUSE OF FUNDS

5.1 Practical Action and the Partner have a zero tolerance approach towards fraud and fraudulent behaviour that may lead to the misuse of funds and will fully co-operate with investigation into

Such events, whether led by Practical Action or the Partner. Practical Action, may, at any time during the term of this arrangement and up to five years after the end of the programme, arrange for additional audits, on-the spot checks and / or inspections to be carried out. These may be carried out by Practical Action, or any of its duly authorised representatives.

5.2 The Partner will comply with Practical Action's Fraud Detection Policy OR confirm that they will comply with their own Fraud Detection Policy, of similar standard. The Partner commits to investigate suspected fraud and to do so with the utmost confidentiality.

5.3 The Partner will immediately and without undue delay inform Practical Action of any event which interferes or threatens to materially interfere with the successful implementation of the project, whether financed in full or in part by this Agreement, including credible suspicion of or actual fraud, bribery, corruption or any other financial irregularity or impropriety.

5.4 Practical Action reserves the ability to recover funds that have been subject to a proven fraud and will work with the Partner to do so. The Partner shall not be obliged to cover such funds unless such fraud is proven to be caused by gross negligence or wilful misconduct of the Partner or its staff members. Where serious fraudulent or unethical activity is proven which would significantly affect the successful completion of the Project, Practical Action reserve the ability to suspend or terminate funding with immediate effect in whole or partial, in preference to the standard notice period and irrespective of any contractual requirements.

Practical ACTION

براكتال أكشن

5.5 Consistent with local and international legislations and applicable United Nations Security Council resolutions both

Practical Action and the Partner are firmly committed to the international fight against terrorism, and in particular, against the financing of terrorism. It is the policy of Practical Action to seek to ensure that none of its funds, including funds that are provided by donors, are used, directly or indirectly, to provide support to individuals or entities associated with terrorism. In accordance with this policy, Practical Action and the Partner make themselves aware of, and comply with obligations under the relevant counter terrorist financing legislations.

ACKNOWLEDGMENT

This to confirmed that I received the Practical Action Safe Guarding Policy Arabic version and by Signing this acknowledgment I confirmed that I read it, understand it, and aware of any consequences resulting in breaching the mentioned Policy.

I also received the Terms and conditions of Practical action read it and understand it.

ارجو ان افيدكم باستلامى لسياسة المنظمة النسخة العربية وبالتوقيع ادناه اقر باننى قد قرأت محتواها وفهمت ما يترتب على مخالفة هذه السياسة من اجراءات. كما افيدكم باستلامى لشروط المنظمة وقرات محتواها وفهمت ما فيه. كما اقر باستلامى لاستمارة تقييم الشركاء والموردين ومقدمى الخدمات وساقوم بملء الاستمارة وارجاعها للمنظمة باعتبارها مطلوبات مانحين.

Name:.....الاسم

Signature:.....التوقيع

Company:.....الشركة

Stamp:.....الختم

Date:.....التاريخ

Practical Action Partner

Due Diligence Questionnaire

Practical Action is committed to upholding the highest possible standards and ethics when delivering our work. This includes protecting staff members and the people living in the communities where we work from exploitation and abuse, protecting ourselves and our donors from financial crime, and ensuring compliance with all donor regulations and local / national laws. We expect the organisations and individuals we work with to uphold the same values and commitments.

In order to work with Practical Action, an organisation must demonstrate that it has the technical capacity, experience, and ability to perform the assigned work, as well as having sufficient processes and procedures in place to ensure it can deliver the work according to the regulations imposed by both Practical Action and the Source Donor.

As part of Practical Action’s due diligence assessment, we need to ensure that your organisation:

- is properly registered with the relevant authorities in your country of operation, and is compliant with national tax requirements;
- has suitable control mechanisms and operational protocols in place to deliver the project activities in line with donor regulations;
- is able to meet Duty of Care obligations to staff, consultants, and people living in the areas where we will work;
- is financially robust and has the necessary policies in place to prevent fraud, financial crime, and terrorist financing

The due diligence assessment is a self-declaration made by you, the potential partner, to provide information regarding your current organisational policies, procedures, registrations, and resources.

It is important that the pre award assessment is completed accurately and truthfully - your organisation will not be automatically disqualified from working with Practical Action if you do not have everything in place. Instead, it allows us to identify areas where we may have to share resources in order to comply with the requirements of major institutional donors - while also providing Practical Action with the assurance that your organisation is compliant with all applicable laws, rules, and regulations, and acts in accordance with the highest standards of ethics.

In the event that Practical Action issues a subaward to your organisation, this declaration should be completed and resubmitted annually ahead of further payments.

When completed, this assessment should be returned to the Practical Action contact point with the relevant supporting documentation. **Please note, failure to complete the assessment will prevent the formation of any bidding agreement and/or may delay the payment of a subaward.**

FOR DFID CONTRACTS ONLY (delete if not applicable)

To ascertain the level of compliancy required by your organisation please provide us with the following information

Current number of contracts with the UK Government and the total value (in GBP)	<i>Number</i>	
	<i>Value (GBP)</i>	

1A: Contact Details for all queries relating to this assessment questionnaire

Name:	
Email:	
Phone:	

1B: Registration

Registered Company Name	
Registered Company Number	
Country of Registration	
Date of Registration	
Head Office DUNS number <i>(if applicable)</i>	
Registered VAT number <i>(if applicable)</i>	
Registered Office Address	
Please indicate your type of organisation	
Ultimate / Parent Company <i>(if applicable)</i>	
Name of subsidiary companies <i>(if applicable)</i>	

1C: Governance and Control

Please provide the following information for your organisation.

Name of Managing Director / Chief Executive Officer	
Names of Company Board Member(s)	
Names of Senior Leadership / Management team	
Name of shareholders and percentage of shareholding <i>(if applicable)</i>	
Names of Affiliated Organisation(s) (if any)	
Does your organisation have an accounting system in place that will enable Practical Action to readily identify the assets, expenses, cost of goods, and use of funds for any subaward we may provide.	Yes <input type="checkbox"/> No <input type="checkbox"/>
Does your organisation have a Quality Assurance (Contract Management) manual, policies, certification and/or systems in place?	Yes <input type="checkbox"/> No <input type="checkbox"/>
Does your organisation maintain a formal risk register and monitor mitigation plans?	Yes <input type="checkbox"/> No <input type="checkbox"/>

1D: Insurance

Please confirm whether you have the following insurance cover in place	Professional Indemnity:	Yes <input type="checkbox"/> No <input type="checkbox"/>
	Public Liability:	Yes <input type="checkbox"/> No <input type="checkbox"/>
	Employer's Liability:	Yes <input type="checkbox"/> No <input type="checkbox"/>
	Travel Insurance:	Yes <input type="checkbox"/> No <input type="checkbox"/>

1E: Duty of Care

As the lead partner, Practical Action are responsible for ensuring our partners and subcontractors have adequate duty of care provisions in place. Please confirm the following stating 'Yes' or 'No' with any relevant explanations.

Does your organisation have travel policy, risk assessment, and emergency procedure in place	Yes <input type="checkbox"/> No <input type="checkbox"/>
Has your organisation got appropriate systems in place to manage an emergency / incident if one arises? <i>Please provide details below</i>	Yes <input type="checkbox"/> No <input type="checkbox"/>

1F: International Aid Transparency Initiative (IATI) - delete section for Partners under level 1
DFID require organisations receiving funding to comply with the International Aid Transparency Initiative (IATI) standards of transparency for their disbursement of UK aid.

Is your organisation registered on IATI?	Yes <input type="checkbox"/> No <input type="checkbox"/>
<i>If Yes, please provide reference number</i>	

1G: Ethical Training

Do your staff undergo ethical training and annual staff updates (including awareness of modern day slavery and human rights abuses).	Yes <input type="checkbox"/> No <input type="checkbox"/>
<i>If No, please confirm that you will be willing to follow and implement Practical Actions ethical training procedures</i>	Yes <input type="checkbox"/> No <input type="checkbox"/>

1H: Cyber Essentials Scheme - delete section for Partners based outside the UK and/or under level 2

Do you have a system to safeguard the integrity and security of your IT and mobile communication systems in line with the HMG Cyber Essential Scheme	Yes <input type="checkbox"/> No <input type="checkbox"/>
--	--

Part 2: Disclosures

Please complete the below disclosure form with a 'Yes' or 'No' in the right hand column

Your organisation must disclose:	
<i>a) If the organisation or any affiliated companies</i>	
...are or have been the subject of any proceedings or other arrangements relating to bankruptcy, insolvency or financial standing.	Yes <input type="checkbox"/> No <input type="checkbox"/>
...have been convicted of any offence concerning professional misconduct.	Yes <input type="checkbox"/> No <input type="checkbox"/>
...has not fulfilled any obligations relating to the payment of social security contributions.	Yes <input type="checkbox"/> No <input type="checkbox"/>
...have had any media coverage (including online or print) that could impact the reputation of Practical Action or its clients	Yes <input type="checkbox"/> No <input type="checkbox"/>
<i>If you have replied Yes to any of the above please provide details below:</i>	
<i>b) If your organisation, affiliated companies or an employee (past and present within the last 10 years) has been convicted of, or are the subject of any proceedings, relating to...</i>	
...participation in criminal organisation.	Yes <input type="checkbox"/> No <input type="checkbox"/>
...corruption including the offence of bribery	Yes <input type="checkbox"/> No <input type="checkbox"/>
...fraud including theft, and not fulfilling any obligations relating to payment of taxes.	Yes <input type="checkbox"/> No <input type="checkbox"/>
...terrorist offences or offences linked to terrorist activities	Yes <input type="checkbox"/> No <input type="checkbox"/>
...money laundering and terrorist financing	Yes <input type="checkbox"/> No <input type="checkbox"/>
...child labour and other forms of trafficking in human beings	Yes <input type="checkbox"/> No <input type="checkbox"/>

Practical ACTION

پراکٹیکل ایشن

...breach of environmental obligations	Yes <input type="checkbox"/> No <input type="checkbox"/>
...breach of social obligations	Yes <input type="checkbox"/> No <input type="checkbox"/>
...breach of labour law obligations	Yes <input type="checkbox"/> No <input type="checkbox"/>
... are subject of any proceedings, that may be listed by the World Bank in its 'Listings of Ineligible Firms' or "Listings of Firms, Letters of Reprimand' posted at or on any similar list maintained by any other donor of development funding, or any contracting authority.	Yes <input type="checkbox"/> No <input type="checkbox"/>
<i>If you have replied Yes to any of the above please provide details below:</i>	
b) Modern Slavery Act 2015: Requirements under Modern Slavery Act 2015 and UN Global Compact Requirements for active participation.	
Are you a relevant commercial organisation as defined by Section 54 ("Transparency in supply chains etc.") of the Modern Slavery Act 2015 ("the Act") ?	Yes <input type="checkbox"/> No <input type="checkbox"/>
If yes , are you compliant with the annual reporting requirements contained within Section 54 of the Act 2015? <i>Please provide link to URL:</i>	Yes <input type="checkbox"/> No <input type="checkbox"/>
Is your organisation an active participant of the UN Global Compact? If yes , please provide link to URL:	Yes <input type="checkbox"/> No <input type="checkbox"/>

Part 3: Please indicate 'Yes' or 'No' as to whether your organisation has documented policies and procedures for the following matters.

Recruitment policy, procedures and/or organisational HR manual incorporating the following: - Fair recruitment practices - Due diligence and reference assessment - Equal opportunities	Yes <input type="checkbox"/> No <input type="checkbox"/>
Quality Assurance policy, procedures and/or certification	Yes <input type="checkbox"/> No <input type="checkbox"/>
Duty of Care policy and procedures	Yes <input type="checkbox"/> No <input type="checkbox"/>
Finance manual / Protection from Financial Crime policy or equivalent	Yes <input type="checkbox"/> No <input type="checkbox"/>
Gifts and hospitality	Yes <input type="checkbox"/> No <input type="checkbox"/>
Procurement policy	Yes <input type="checkbox"/> No <input type="checkbox"/>
Workforce whistleblowing policy	Yes <input type="checkbox"/> No <input type="checkbox"/>
Safeguarding policy	Yes <input type="checkbox"/> No <input type="checkbox"/>
Anti-bribery/corruption policy	Yes <input type="checkbox"/> No <input type="checkbox"/>
Anti-trafficking/modern day slavery policy	Yes <input type="checkbox"/> No <input type="checkbox"/>
Data protection policy	Yes <input type="checkbox"/> No <input type="checkbox"/>
Duty of Care/Security policy	Yes <input type="checkbox"/> No <input type="checkbox"/>
Environmental policy	Yes <input type="checkbox"/> No <input type="checkbox"/>
Identification and management of conflicts of interest	Yes <input type="checkbox"/> No <input type="checkbox"/>
Health and Safety	Yes <input type="checkbox"/> No <input type="checkbox"/>
Information technology/ data security	Yes <input type="checkbox"/> No <input type="checkbox"/>
Risk management	Yes <input type="checkbox"/> No <input type="checkbox"/>
Code of conduct	Yes <input type="checkbox"/> No <input type="checkbox"/>
If you have answered 'no' to any of the above, please provide confirmation that you will comply with Practical Actions applicable policies and procedures.	Yes <input type="checkbox"/> No <input type="checkbox"/>

Part 4: Declarations

Practical ACTION

پراکٹیکل ایشن

This section is to be completed by the CEO or relevant senior member of your management team.

By signing below I confirm that I (*insert name*) as the (*job title*) of (*insert organisation name*)

- consents to Practical Action running the names of the organisations and individuals listed in section 1C above against international databases as part of our anti-terrorist financing checks
- Confirm that we have adequate processes and systems in place to examine the suitability of sub-contractors to operate on our behalf, and we ensure sufficient oversight of them and their activities to fulfil our contractual obligations.
- Confirm that we are able to provide evidence of due diligence undertaken on our subcontractors if requested, and that we understand Practical Action may conduct spot checks.

FOR DFID FUNDED CONTRACTS ONLY (please delete as appropriate)

- declare that I have read, understood and accept the DFID supply partner Code of Conduct and that appropriate procedures have been put in place to ensure adherence to the Code by all employees, partners and subcontractors within our supply chain.
(<https://www.gov.uk/government/publications/dfids-supplier-review>)
- confirm that my staff and subcontractors have been made aware that any instances of conflict of interest, fraud, unethical behaviour or misconduct should be reported to the DFID reporting concerns mailbox reportingconcerns@dfid.gov.uk

I hereby certify that all information contained within this document is true, correct and not misleading in anyway. I understand that the information will be used in the process to assess my organisations suitability to be selected as a partner and I am signing on behalf of my organisation.

Signature _____

Print Name _____

Job Title _____

Date _____

Please provide a copy of the following documents when returning your assessment questionnaire to us

- ✓ Company registration certificate
- ✓ Proof of tax registration
- ✓ Copy of Audited Accounts for the past 3 years
- ✓ Copy of all insurance certificates as listed in section 1D
- ✓ Copy of project risk register template
- ✓ Cyber essentials certificate (if applicable)
- ✓ 2 Past performance certificates / statements of recommendations from previous donors / clients within the past three years

Copy of the policies/documents listed in Part 3 of this form